

**MODEL ANSWER**

SUMMER- 19 EXAMINATION

Subject Title: ENGINEERING DRAWING

Subject Code:

22207

**Important Instructions to examiners:**

- 1) The answers should be examined by key words and not as word-to-word as given in the model answer scheme.
- 2) The model answer and the answer written by candidate may vary but the examiner may try to assess the understanding level of the candidate.
- 3) The language errors such as grammatical, spelling errors should not be given more Importance (Not applicable for subject English and Communication Skills).
- 4) While assessing figures, examiner may give credit for principal components indicated in the figure. The figures drawn by candidate and model answer may vary. The examiner may give credit for any equivalent figure drawn.
- 5) Credits may be given step wise for numerical problems. In some cases, the assumed constant values may vary and there may be some difference in the candidate's answers and model answer.
- 6) In case of some questions credit may be given by judgement on part of examiner of relevant answer based on candidate's understanding.
- 7) For programming language papers, credit may be given to any other program based on equivalent concept.

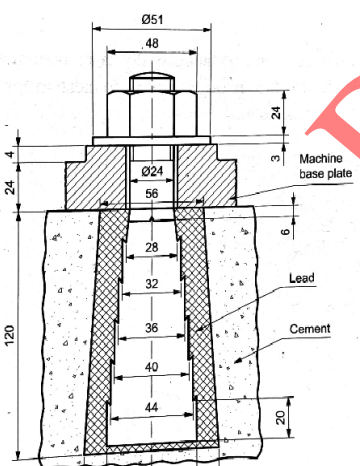
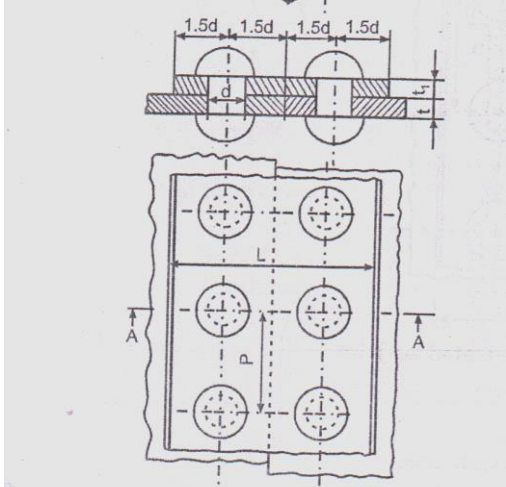
Q. No.	Sub Q. N.	Answer	Marking Scheme
1		<p>a) Rag foundation bolt</p>  <p>b) Single Rivetted, Single Strap Butt Joint</p> 	<p>Any five</p> <p>02 Marks each</p>

OUR CENTERS :

KALYAN | DOMBIVLI | THANE | NERUL | DADAR

Contact - 9136008228

c) Muff coupling

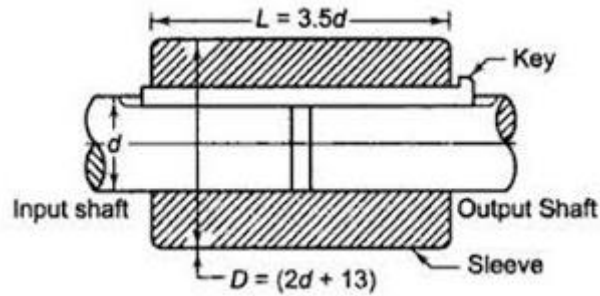

d) Wood

Metal (Steel)

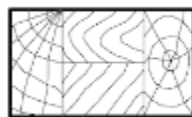

Wood, plywood, etc.



Metals like steel, cast iron, copper and its alloy, aluminium and its alloy, etc.

e) i) ALL ROUND FILLET WELD

ii) Single V-Butt



f) i) FALSE

ii) TRUE

g) Removed Section

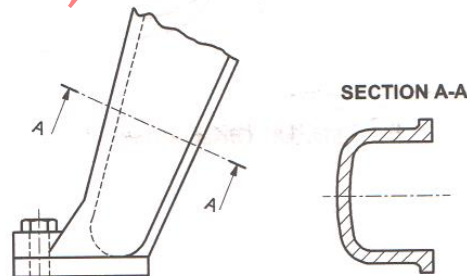

It is similar to revolved type of section except that it does not appear on the view. Here the section is shown to some adjacent open place on the drawing. Removed sections of symmetrical parts are placed on the extension of the center line wherever possible.

2

a

Line problem

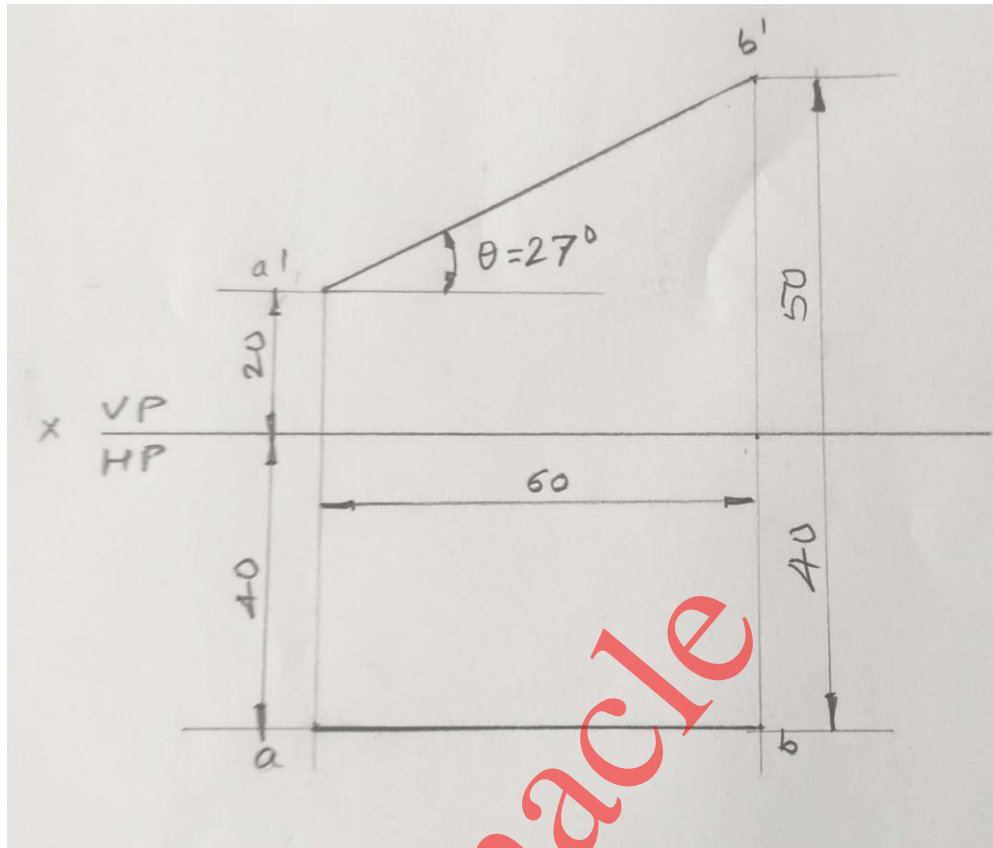

04  
Marks  
for  
correct  
answer

b

Circular plate

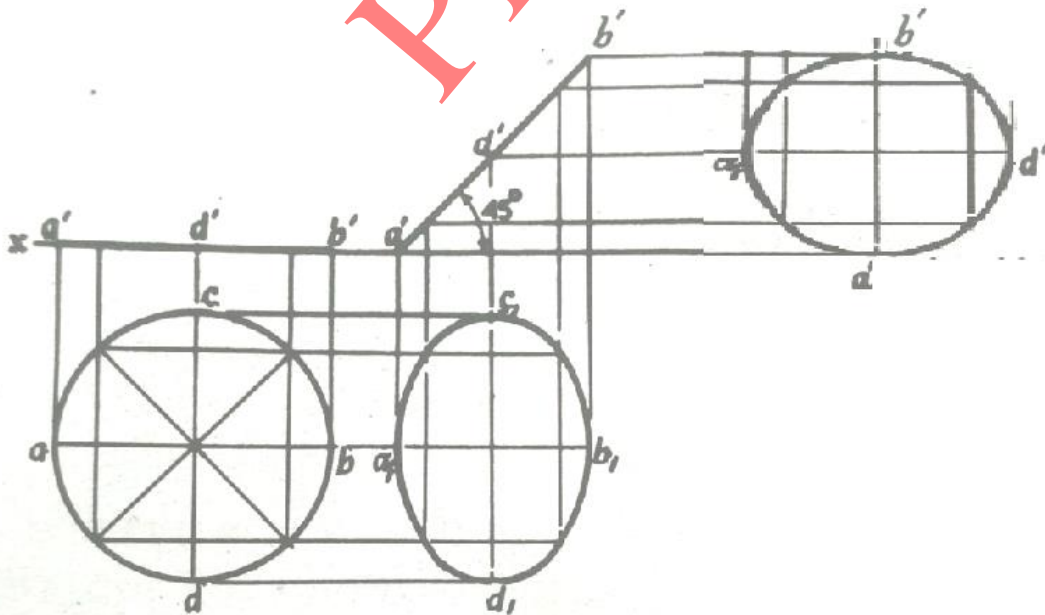

04  
Marks  
for  
correct  
answer

c

Pentagonal prism

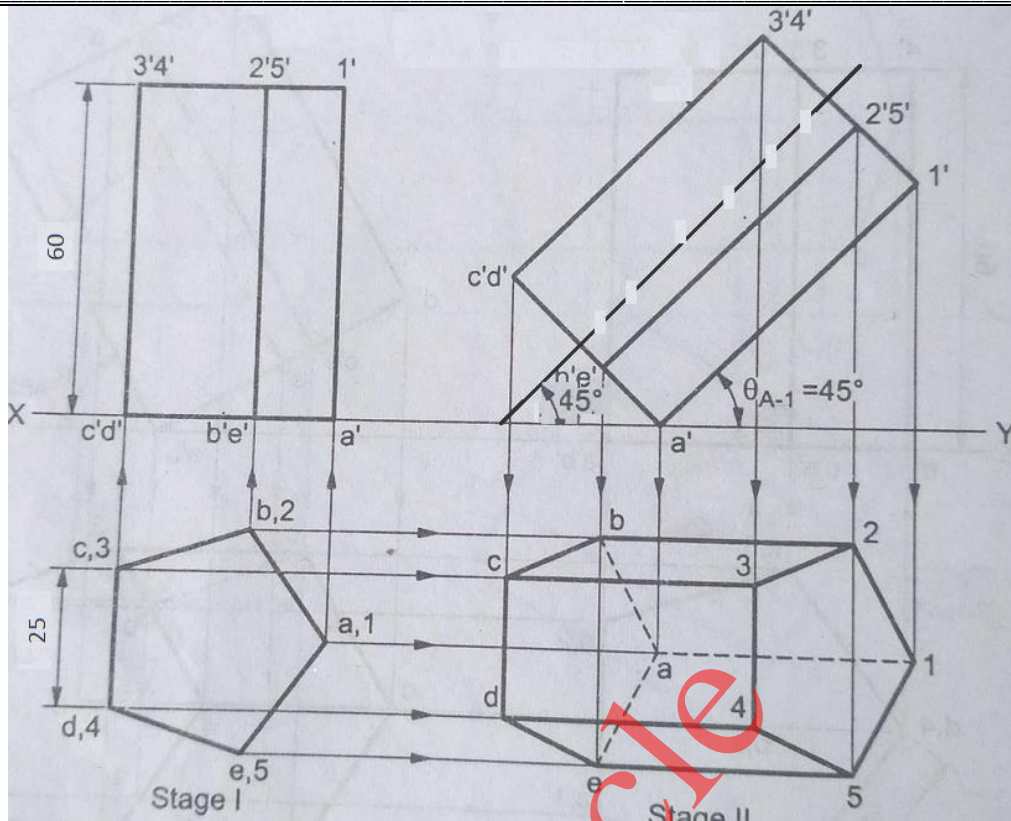

04  
Marks  
for  
correct  
answer

d Set square

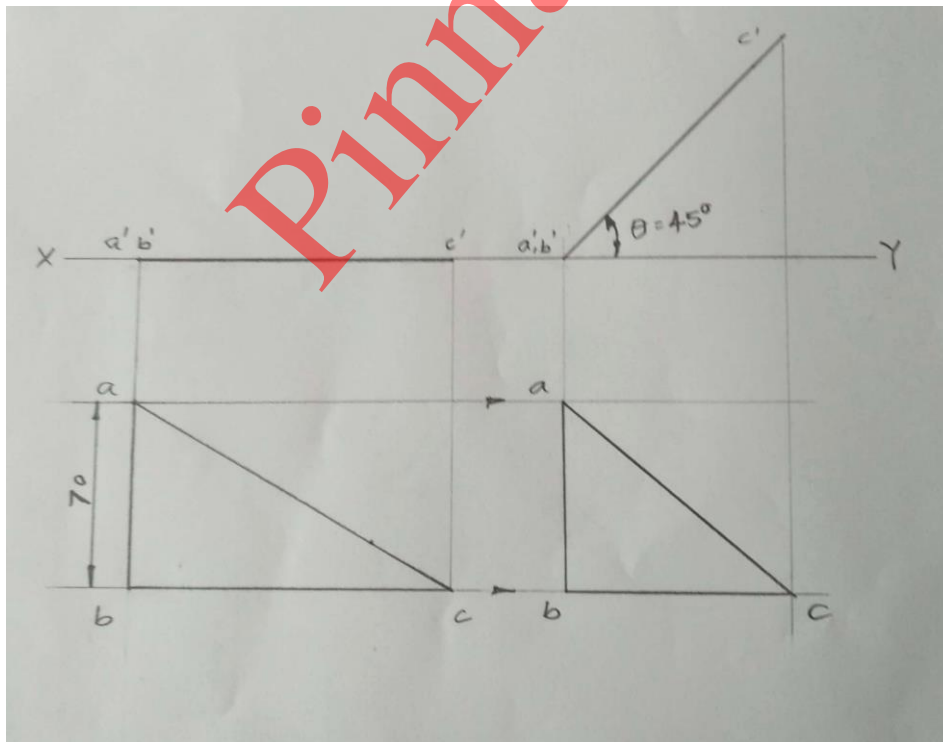

04  
Marks  
for  
correct  
answer

04

3

e

TOP VIEW OF BASE IS **ELLIPSE**

Marks

a

**03 Marks for Initial position and 05 Marks for Final position**

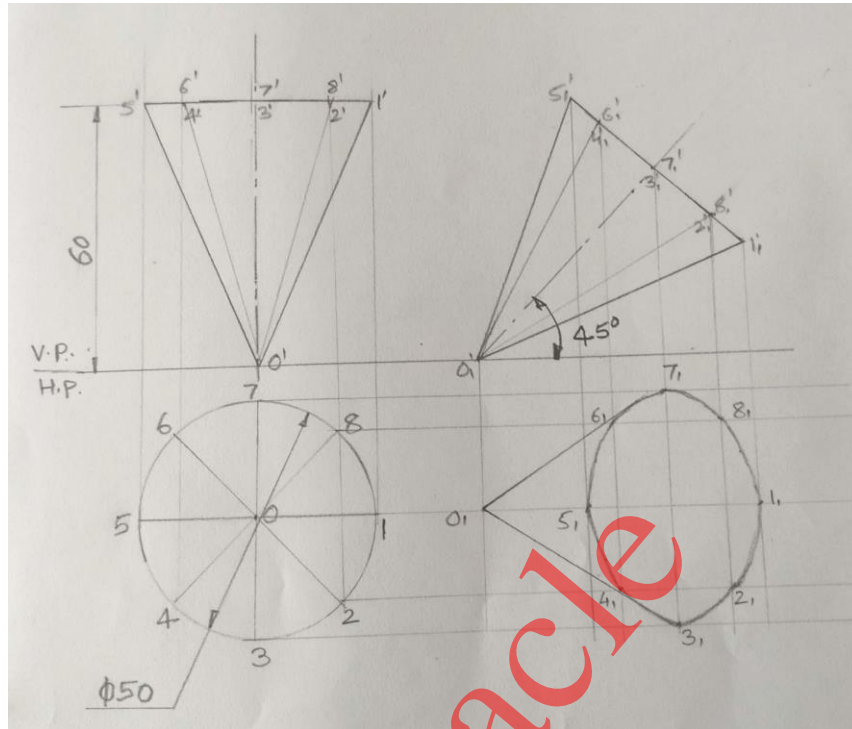

b

**02 Marks for F.V 03 Marks for S.T.V and 03 Marks for True shape of section**

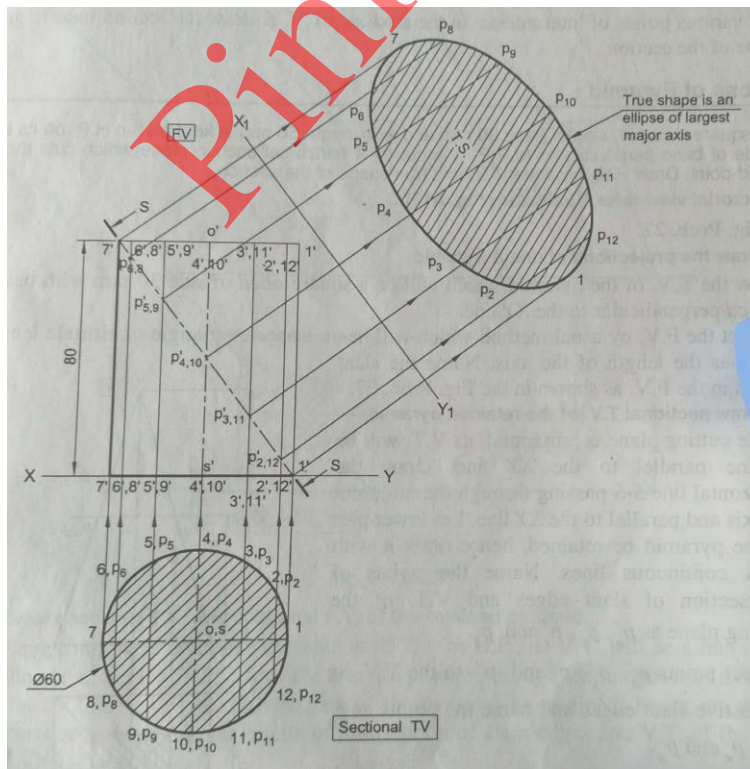

**OUR CENTERS :**

**KALYAN | DOMBIVLI | THANE | NERUL | DADAR**

**Contact - 9136008228**

c 02 Marks for F.V 03 Marks for S.T.V and 03 Marks for True shape of section

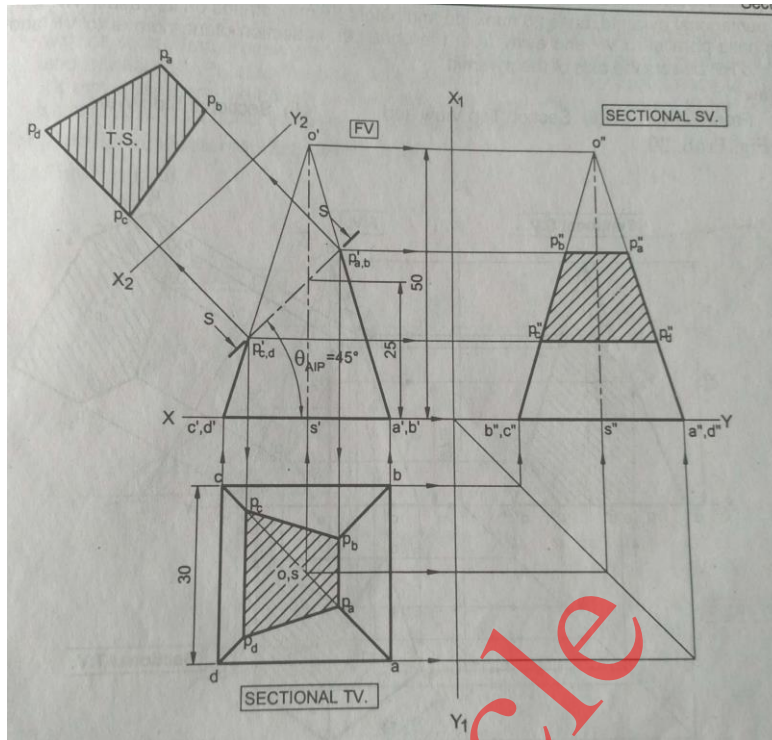

4

a 04 Marks for Sectional front view and 04 Marks for Sectional Top view

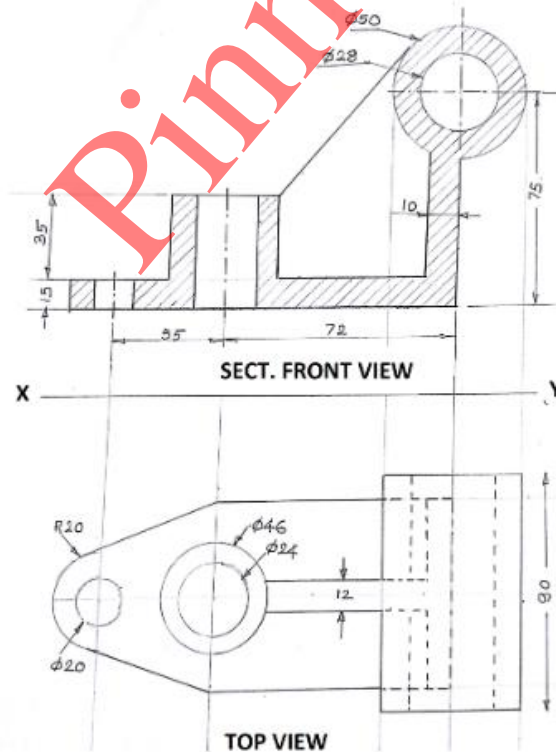

b 04 Marks for Sectional front view and 04 Marks for Top view

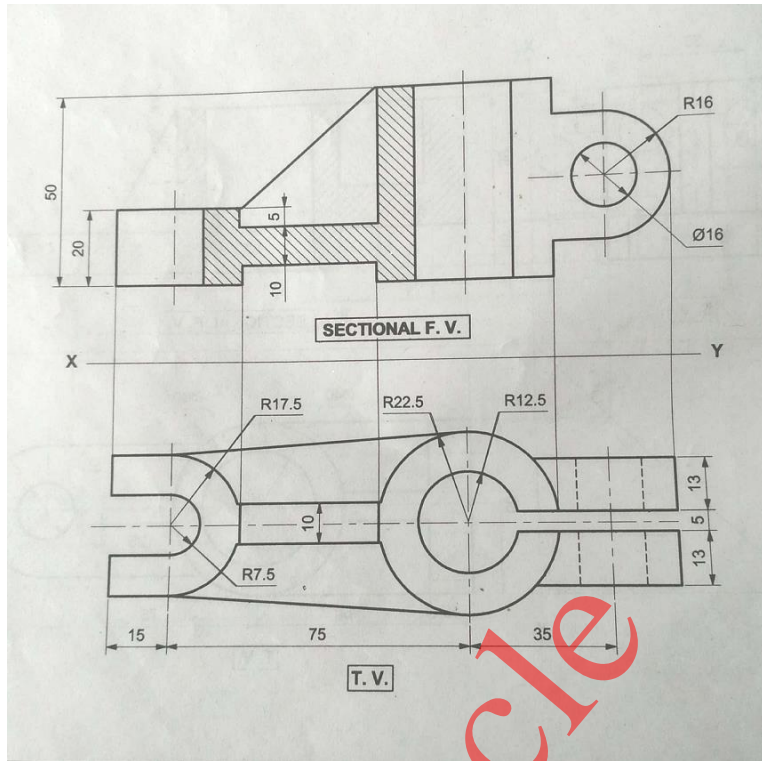

c 02 Marks for Front view, 02 Marks for Aux. view and 04 Marks for Side view

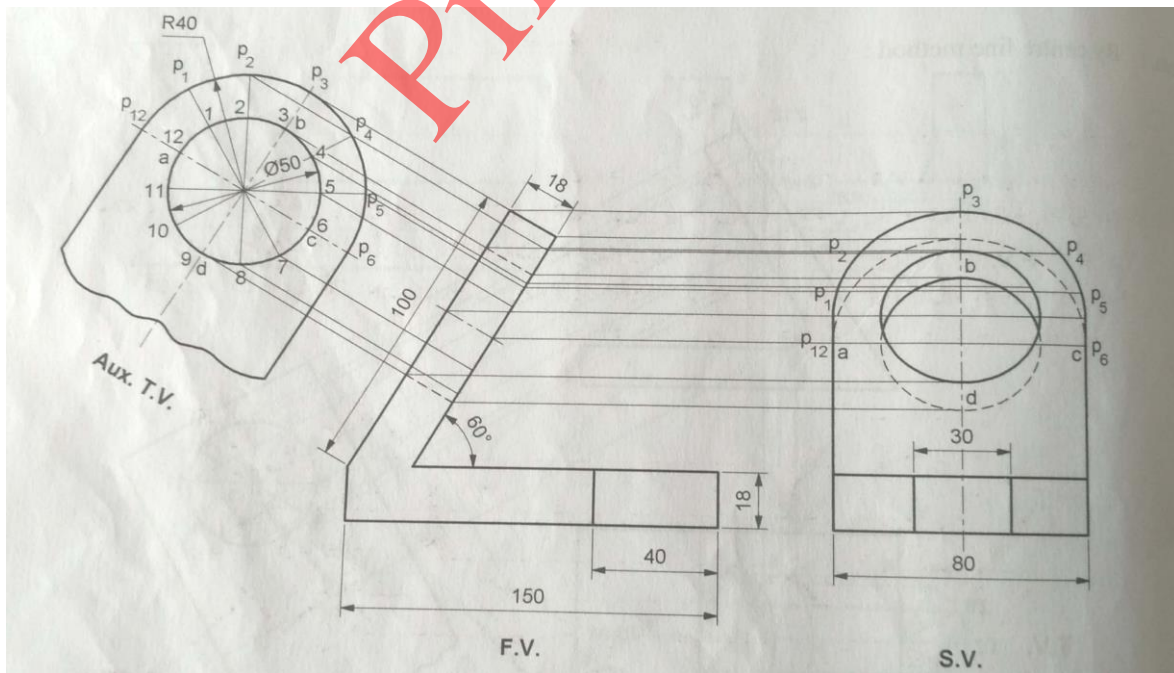

5

a

02 Marks for Front view, 02 Marks for Top view and 04 Marks for left hand Side view

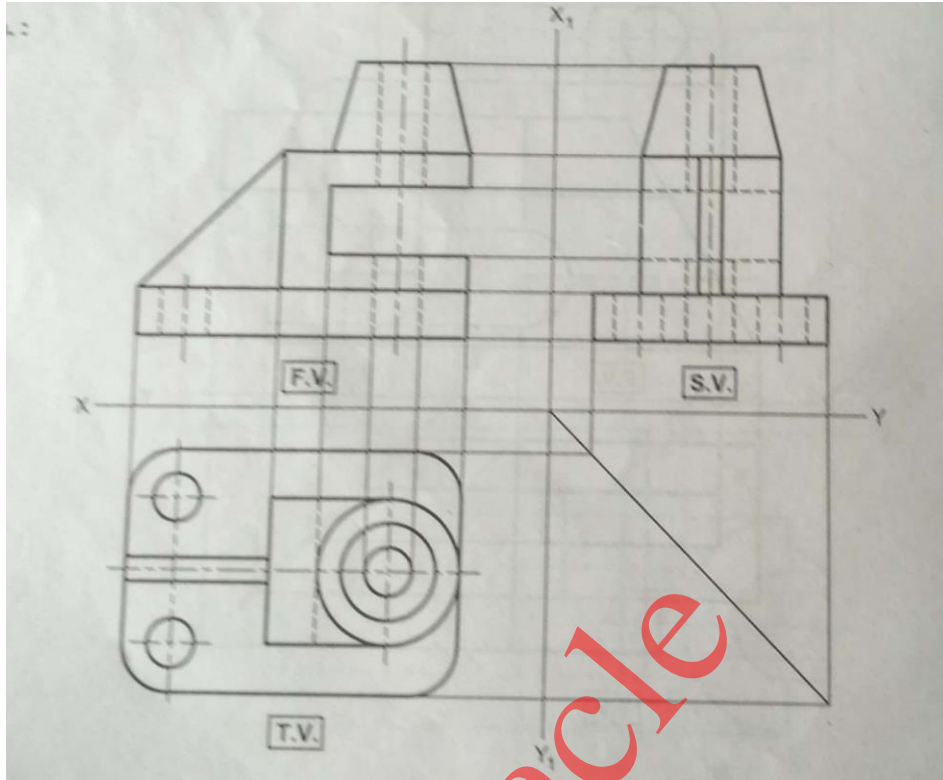

b

02 Marks for sect. Front view, 02 Marks for Top view and 04 Marks for left hand Side view

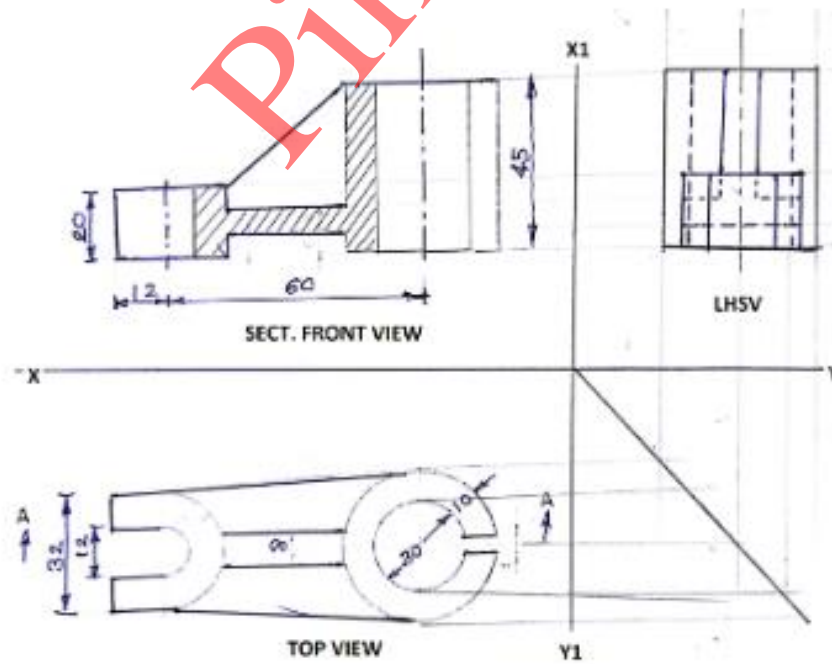

OUR CENTERS :

KALYAN | DOMBIVLI | THANE | NERUL | DADAR

Contact - 9136008228



c 04 Marks for Front view, 02 Marks for Aux. view and 02 Marks for Top view

